

PRODUCT CATALOG

EDITION.1

Powder Level Switch
Powder & Liquid Level Switch
Non-Contact Level Meter
Flow Sensor
Contact Level Meter
Liquid Level Meter & Switch
Conveyor Peripherals
and more...



KANSAI
Automation

CONTENTS

Powder Level Switch	2-3
Powder & Liquid Level Switch	4
Non-Contact Level Meter	5
Flow Sensor	5
Contact Level Meter	6-7
Liquid Level Meter & Switch	8
Conveyor Peripherals	9
Certified Explosion-proof Instruments: Usable Range Of Explosive Gas	10
Chemical Resistance Table	11
Characteristic Table of Fluorocarbon Resin	12
Table of Recommended Sensitivity and Specific Inductive Capacity for Capacitance Type Level Switch	13-14

Powder Level Switch

Swing Type Level Switch

Epoch-making product of Powder level detection.

Newly developed "SWING MASTER"
Future standard level switch for powder.



Swing!!

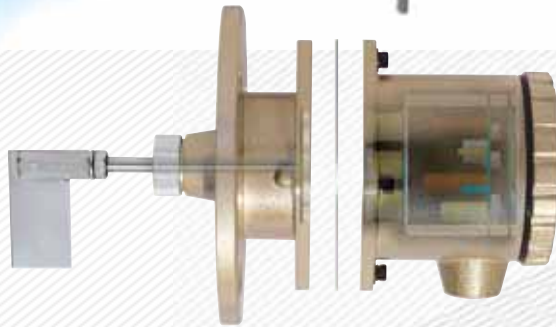

Unique and ideal level switch for power application is born from our many years of experience and technique.

SWM Series SWINGMASTER®

Highly functional as well as cost effective.
Versatile enough to be used for any applications.



SWM-8B



SWM-8BSC

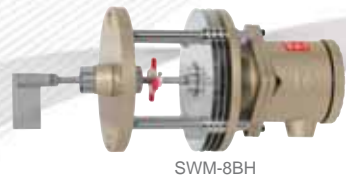

SWM-8BH



SWM-8BS



SWM-15B



SWM-8B SUS

Universal power supply AC100~240V (Applicable range AC85~250V)

Powder Granules

Rotary Paddle Type Level Switch

NL/NM Series

Standard type for detecting powder, versatile usages.

Powder Granules

DC24V Available



FL-GM Series

Flame-proof
d2G4



NNL/NNM Series

Expendable parts in a motor removed and developing the original switching structure developed.

Motor unit operates reliably for a long period of time.

Reversible Paddle Type

Powder Granules

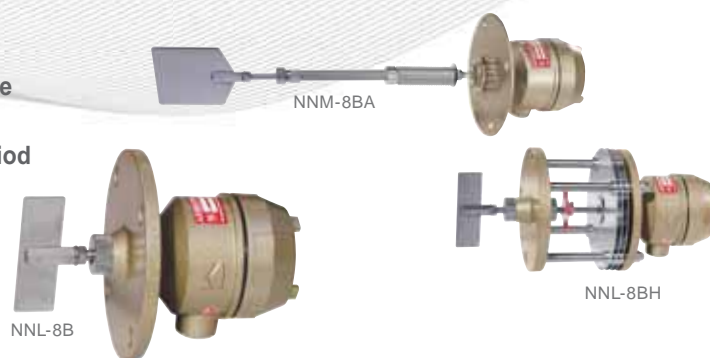

LEMICON Series

Compact, light weight, and lowest price on top of high efficiency and quality.

Extremely Compact Type

Powder Granules

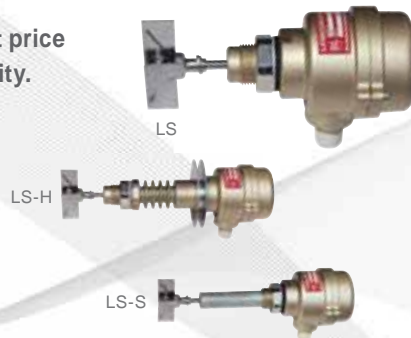

Microwave Type Level Switch

MWS2-24TN/24RN Type

The attenuation of microwave detects levels of powder, granules and blocks as well as pulverized materials.

Heat-resistant type is available.

Powder Granules Lump

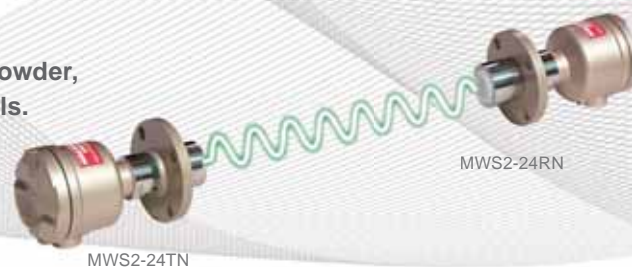

Powder & Liquid Level Switch

Capacitance Type Level Switch

ALN Series

Extremely high-stable & reliable detection Versatile level switch being used for many applications.

Powder **Granules** **Liquid**
Surface Interface

ALN-11 - H
Super Heatproof Type

ALN-155-
Pipeline Type

ALN-12 -
Teflon-coated Type

ALN-131-
Flat Type

ALN-14 -
Wire Type

Straight-rod Type
ST8 -11 -

Intrinsically safe
(ST81 ia3nG1
ST82 ia3nG2
ST85 ia3nG5)

ST8 Series

Certified as the Intrinsically Safe Explosion-proof can be accommodated to any shape of electrode.

Intrinsically safe
ia3nG5

Barrier relay
(Power supply unit)
PS8

Remote model
Amplifier

Vibration Type Level Switch



KVK Series

A single vibrating probe realizes as delicate vibration as tuning fork. High reliable detection and various product line.

High Sensitivity Type



KVK-111

KVK-36



KVA/KVF Series

Our own technology has made it possible to line up series of withstand-load probe that can still come with delicate vibration.

Withstand Load Type



KVA-111

KVA-13



KVF-121

Remote model
Amplifier

Liquid **Underwater Solid** **Powder** **Granules**

KVX Series

Pursuing simple operation. Our own technology realizes more stable vibration with new physical principle.

Compact

KVX-111

KVX-112-3

KVX-211

XV2 Series

Extremely compact and light suitable for such a place as the compact size is required in particular.

Extremely Compact Type

XV2-111

XV2-121

XV2-211

Powder **Granules** **Liquid**



Non-Contact Level Meter

Laser Type Level Indicator

Best suitable for non-contact measurement at the places where it is highly difficult or dangerous to measure!



LASER RANG-S

Class 2

Extremely compact Laser Type Level Meter that can measure up to 10 meters by pinpoint.

Powder Granules Liquid



Compact

With long wavelength and very small beam divergence, laser level meter measures pinpoint, avoiding the obstacles.

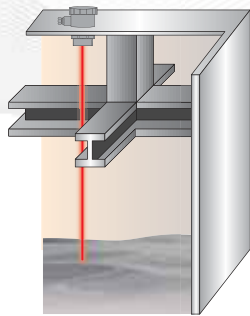

Pinpoint measurement

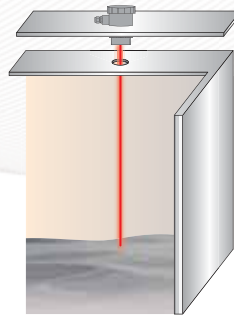

Measurement through the hole

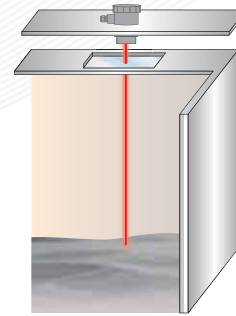

Measurement through the window

Flow Sensor

Microwave Type Flow Sensor

KFD-1/KFD-2

24GHz helps this sensor be highly sensitive and reliable. It does not overlook even a grain.

Powder Granules

Particle Flow Sensor

KDS-1

Concentration Monitoring of exhausted dust and minute particles and detecting flow/no flow.

Powder Granules

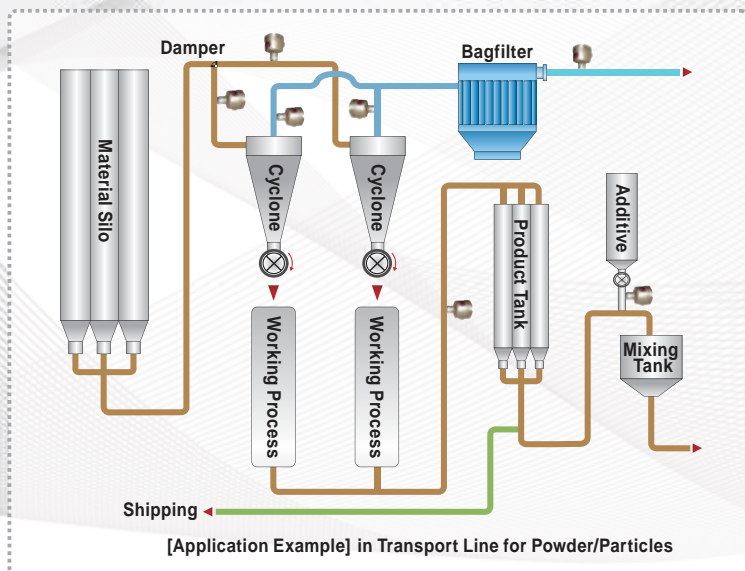

Contact Level Meter

Sounding Type Level Indicator

Various product lines.

They can be applied to all processes, and they are the best selling lines for their reliability.



KSL-T2

SPAN : MAX40m

Standard

- Powder
- Granules
- Lump
- Underwater Solid



KSL-W2B

SPAN : MAX20m

Standard

- Powder
- Granules
- Underwater Solid

Optional Units

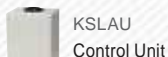

KSLAU
Control Unit



PSC
P/I
Converter



KSL-W3T

SPAN : MAX20m

Standard

- Powder
- Granules
- Underwater Solid

CPU built-in models. Upgraded models are all weathertight constructions with aluminum casting body.



KSL-T8

SPAN : MAX40m

Build-in CPU

- Powder
- Granules
- Lump
- Underwater Solid



KSL-MT

SPAN : MAX20m

Build-in CPU

- Powder
- Granules
- Underwater Solid

Sounding Type Level Indicator Controls

A controller controls many units (4 for DS4). Selecting a tank with one-touch operation. Memory function is equipped.

Microprocessor Control System

KSL-DS4

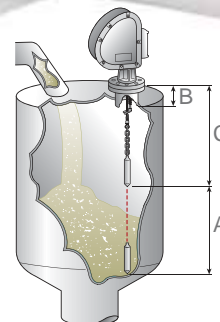
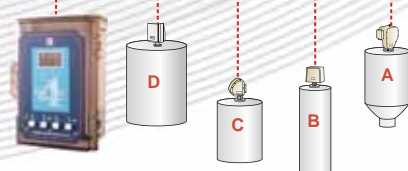

A. Measuring Range
B. Height of Nozzle
C. Roll-up Position

Contact Level Meter

Capacitance Type Level Indicator

No moving part. It can be applied to any processes.
Best selling line in continuous measurement

Various kinds of electrode that can be provided for hazardous places.

Electrode · Amplifier
Remote Type
KLI Series

KLI-4
Cable with
TEFLON-coating



Electrode · Amplifier
Built-in Type
KLT Series

KLT-2
TEFLON-tubing
probe

KLI-2
TEFLON-tubing probe



KLT-1
Bare probe



Intrinsically safe
explosion-proof model
KLG Series

Intrinsically safe
(i)2G4

KLG-2 3
TEFLON-tubing
probe

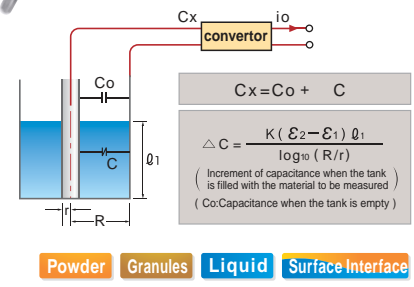
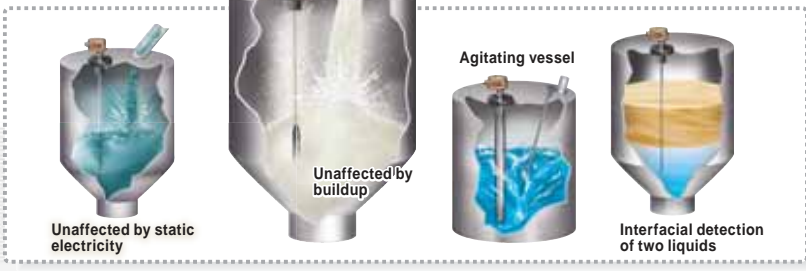

Powder Granules Liquid Surface Interface

Vertical Float Type Level Indicator

KF-100 Series Resistance type

It is not at all affected by environmental conditions such as material changes, gas and so on. Pioneer of Liquid Level Indicator

Intrinsic safety
Exia CT5



KF-900 Series Magnetostrictive type

Highly accurate float level meter

Intrinsic safety
Exd CT6

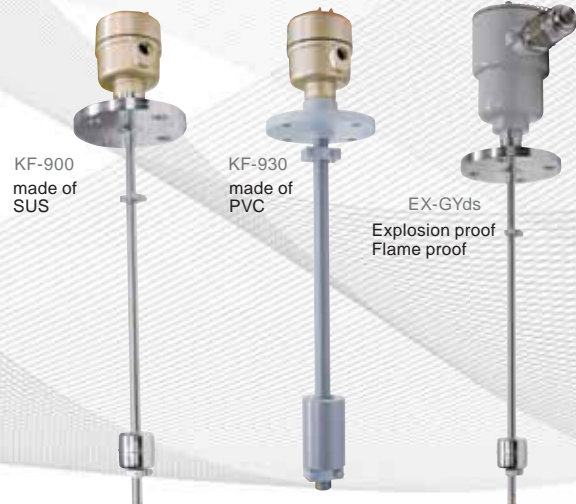

Horizontal Float Type Level Switch

Many products upgraded depending on application and installation. Best selling line for its reliability.

KF200 Series



KFG200 Series

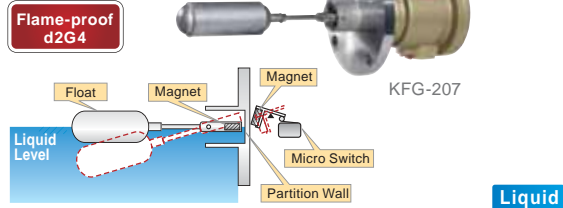

Compact Float Switch

Multi-point-measurement Type

Most ideal for an ultra-small tank



One-point-measurement Type

Palm-sized Switch

Vertical Float Type Level Switch

These can be applied to all processes with various sizes and materials.

KFE-3000 Series

Flame-proof
Exd BT4

KF-300 Series

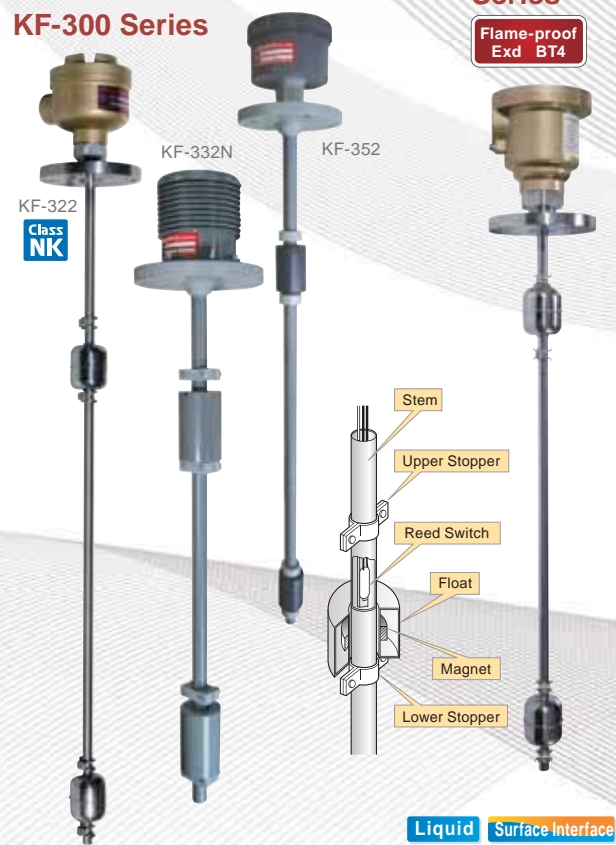

Diaphragm Type Level Switch

KF500 Series

Can be used for viscous liquids as well as high temperature liquids. Diaphragm can reliably detect level.

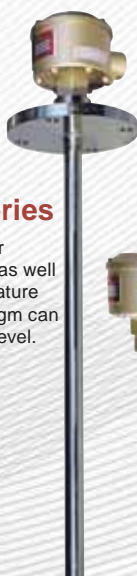

Electrode Type Level Switch

KF-600 Series

Various materials of electrode can satisfy any applications.



Multi-point Ball Float Switch/ KARI Float Switch



It perfectly detects levels of wastewater and viscous liquids with its incomparable buoyancy.

Liquid

Conveyor Peripherals Switch

KP-800 Series

Ensuring safety operation of Conveyor Lines

KP-850-1

KP-850-2

Standard

Powder Granules Lump



KP-860

Indication Plate



KP-870

Indication Plate



Detecting operational exceptions such as belt moving off to one side.

KP-880



KP-810

KP-4

KP-850

KPS-123/124

KP-880

KP-820

KP-830



KEL-2

MWS2-24TN

TC-3

MWS2-24RN

KFD-1

Leak Type Level Switch

KEL-2 Series

Insulator

No moving part. Suitable for measuring sand. Applicable to aggregate, limestone and so on.



AMP

Powder Granules Lump



Tilt Switch

Simple mechanical construction tough enclosure. Level measurement with simple and reliable operation



TC-1

TC-3

TCシリーズ

Powder Granules Lump

PL-910

PL-920

PL Series



Speed Detector

Reliably catching changes of conveyor speed, preventing motor and other components from being damaged.

KPS Series



KPS-21

Non-contact Type

KPS-11

Directly Connected to Shaft



KPS-123/124

Touch-roll Type

Powder Granules Lump

Flow Switch

KP-800 Series

Flow detection of powder and granules on a conveyor.



KP-4

KP-810

KP-820



KP-830

Powder Granules Lump

Certified Explosion-proof Instruments: Usable Range Of Explosive Gas

National Standard

d 2 G4

- Ignition level : G1-G5
- EXP-proof grade : 1-3
- EXP-proof construction
 - d : Withstand pressure Exp-proof
 - e : Safety-increased EXP-proof
 - i : Intrinsic Safety EXP-proof
 - f : Pressurized construction
 - o : Oil filled EXP-proof
 - s : Special EXP-proof

International Standard

Ex d B T4

- Surface Temp. Class: T1-T6
- Surface industries: IIA, IIB, IIC
- Flameproof enclosure type
 - g : Withstand pressure Exp-proof
 - e : Safety-increased EXP-proof
 - ia, ib : Intrinsic Safety EXP-proof
 - p : Pressurized construction
 - o : Oil filled EXP-proof
- Explosion-proof equipment (IEC)

Ignition Temp. of Explosive Gas	Over 450°C	Over 300°C Below 450°C	Over 200°C Below 300°C	Over 135°C Below 200°C	Over 100°C Below 135°C	Over 80°C Below 100°C	
Temperature Grade	T1	T2	T3	T4	T5	T6	
Ignition Level	G1	G2	G3	G4	G5	G6	
Steam Category IIA	Explosion Grade 1	Acetone	Ehtanol	Gasoline	Acetaldehyde		Ethyl nitrite
		Ammonia	Isoamyl acetate	Hexane	(Di)ethyl ether		
		Carbon monoxide	Pranolol	Butyl chloride	Dibutyl ether		
		Ethane	Butane	Octane			
		Acetic acid	Acetic anhydride	Cyclohexane			
		Ethyl acetate	Methyl acrylate	Dimethyl ether			
		Acetonitrile	Ethyl acrylate	Tetrahydrofuran			
		Isopropyl chloride	Isooctane	Decane			
		m-xylene	Isopentane	Hexanol			
		Chlorobenzene	Vinyl chloride	Heptane			
		Hydrogen cyanide	Vinyl acetate	Pentanol			
		Dichloroethylene	Propyl acetate	Pentane			
		Trimethyl benzene	Cyclohexane	Methyl hexane			
		Toluene	Acetylacetone				
		Propane	Isobutanol				
		Benzene	Epichlorohydrin				
		Methanol	Isopentyl acetate				
		Methane	Butyl acetate				
		Acrylic nitrile	Pentyl acetate				
		Ethyl Methyl Ketone	Diisopropyl ether				
O-xylene	Dioxane						
P-xylene	Dichloroetane						
Methyl acetate	Thiophene						
Ethyl bromide	Furan						
Styrene	Propanol						
Benzotrifluoride	Propylene						
Steam Category IIB	Explosion Grade 2	Coal gas	Ethylene	Isopropylene			
		Dichloroethylene	Propylene oxide	Hydrogen sulfide			
		Ethylene oxide					
		Butadiene					
Steam Category IIC	Explosion Grade 3	Water gas	Acetylene		Carbon bysulfide	Ethyl sulfate	
		Hydorgen					

Chemical Resistance Table

Chemicals	Material					
	PVC	PA	PP	FEP	PFA	SUS
Acetone	x	x	x	A	A	A
Aniline	x	B	B	A	A	A
Amyl alcohol	B	B	B	A	A	-
Ammonia water (10%)	B	A	A	A	A	A
Ammonia water (28%)	B	A	A	A	A	A
Isopropyl alcohol	B	B	B	A	A	A
Ethyl alcohol (50%)	B	A	B	A	A	A
Ethyl alcohol (95%)	B	B	B	A	A	A
Ethyl glycol	B	A	A	A	A	B
Zinc chloride	A	A	A	A	A	x
Aluminum chloride	A	A	A	A	A	x
Ammonium chloride	A	A	A	A	A	-
Kalium chloride	A	A	A	A	A	x
Calcium chloride	A	A	A	A	A	B
Ferric chloride	A	A	A	A	A	x
Magnesium chloride	A	A	A	A	A	B
Methylene chloride	x	x	x	A	A	B
Hydrochloric acid (10%)	A	A	A	A	A	x
Hydrochloric acid (35%)	A	A	A	A	A	x
Perchloric acid	B	B	B	A	A	x
Hydrogen peroxide (10%)	A	A	A	A	A	B
Hydrogen peroxide (3%)	A	A	A	A	A	A
Potassium permagnate	A	A	A	A	A	B
Formic acid	A	A	A	A	A	x
Xylene	x	x	x	A	A	A
Citric acid	A	A	A	A	A	A
Cresol	A	x	x	A	A	A
Chromic acid (10%)	B	B	B	A	A	x
Chromic acid (50%)		x	x	A	A	x
Chloroform	x	x	x	A	A	A
Acetic acid (50%)	A	A	A	A	A	A
Acetic acid (80%)	A	B	B	A	A	x
Acetic ether	x	x	x	A	A	B
Sodium hypochlorite	A	B	B	A	A	A
Carbon tetrachloride	x	x	x	A	A	B
Dimethylformamide	x	A	A	A	A	A
Oxalic acid	A	A	A	A	A	x

Chemicals	Material					
	PVC	PA	PP	FEP	PFA	SUS
Nitric acid (10%)	A	A	A	A	A	x
Nitric acid (50%)	B	A	A	A	A	x
Caustic silver	A	A	A	A	A	B
Sodium nitrate (10%)	A	A	A	A	A	A
Vegetable oil	B	A	A	A	A	A
Sugared water	A	A	A	A	A	A
Sugared water (alkali)	A	A	A	A	A	B
Potassium hydroxide (45%)	A	A	A	A	A	B
Potassium hydroxide (5%)	A	A	A	A	A	B
Sodium hydroxide (1%)	A	A	A	A	A	B
Sodium hydroxide (10%)	A	A	A	A	A	B
Sodium hydroxide (50%)	A	B	B	A	A	B
Stearic acid	A	B	B	A	A	A
Oil	B	x	x	A	A	A
Ammonium carbonate	A	A	A	A	A	A
Sodium carbonate	-	A	A	A	A	A
Kerosene	A	x	x	A	A	A
Toluene	x	x	x	A	A	A
Lactic acid	A	A	A	A	A	A
Picric acid	B	B	B	A	A	x
Phenol (50%)	-	A	A	A	A	A
n-butyl alcohol	A	A	A	A	A	-
Hydrofluoric acid (10%)	A	A	A	A	A	x
Hydrofluoric acid (50%)	A	A	A	A	A	x
Benzene	x	x	x	A	A	A
Boric acid	A	A	A	A	A	A
Formaldehyde (gas)	B	A	A	A	A	B
Methyl alcohol	B	A	A	A	A	A
Methyl ethyl ketone	x	x	x	A	A	A
Sulfuric acid (10%)	A	A	A	A	A	x
Sulfuric acid (50%)	B	A	A	A	A	x
Sulfuric acid (98%)	B	A	A	A	A	x
Ammonium sulfate	A	A	A	A	A	B
Phosphoric acid (10%)	A	A	A	A	A	B
Phosphoric acid (50-80%)	B	A	A	A	A	B
Ammonium phosphate	A	A	A	A	A	B
Sodium phosphate	A	A	A	A	A	-

A = Good B = dependent on conditions x = Unusable

Characteristic Table of Fluorocarbon Resin

Abbreviation	PTFE (4F)	FEP (6F)	PFA	PVDF (2F)
Name	Polytetra Fluoro Etylene	Perfluoroethylene-Propylene Copolymer	Tetrafluoroethylene-Perfluoroalkoxy Vinyl Ether Copolymer	Polyvinylidene Fluoride
Continuous Temp. Limit (°C)	260	200	260	150
Pull Strength (Mpa)	13.7 – 34.3	16.6 – 21.6	27.5 – 29.4	24.5 – 50.0
Affected by weak acid	No	No	No	No
Affected by strong acid	No	No	No	Corroded by fuming sulfuric acid
Affected by weak alkali	No	No	No	No
Affected by strong alkali	No	No	No	No
Affected by organic solvent	No	No	No	Almost resistant
Affected by direct sunlight	No	No	No	No
Application-Features	Anti-corrosion materials for chemical-plant fixtures, non-adhesive applications, non-greased bearings and electric insulation of jet aircrafts.		Machinery parts requiring anti-corrosion, intensity and transparency.	Anti-corrosion and electric insulating materials requiring flammability
Models applied	<ul style="list-style-type: none"> ●Insulator for Capacitance model ●Insulator for Dust Monitor 	<ul style="list-style-type: none"> ●Teflon-tube for Capacitance model (Standard: Max120°C) 	<ul style="list-style-type: none"> ●Teflon-tube for Capacitance model (Special :Max150°C) ●Wire-tube for Capacitance model 	<ul style="list-style-type: none"> ●Transmitting device for Ultrasonic Transmitter

*The above characteristic table shows the features of fluorocarbon resin alone. When it is incorporated into a product, its heat resistant temperature and strength may be varied so that the performance level. may be maintained

Table of Recommended Sensitivity and Specific Inductive Capacity for Capacitance Type Level Switch

	Name of Object	SIC	S
A	Acrylic Rubber	4	1
	Acetate	3.2 ~ 7.0	1
	Acetic acid	6.1 ~ 6.7	1
	Acetic anhydride	22	2
	Acetum,	38	2
	Acrylic Resin	2.7 ~ 4.5	1
	Alcohol	16 ~ 31	2
	Aluminum fluoride	2.2	1
	Amber	2.8 ~ 2.9	1
	Aminoalkyl Resin	3.9 ~ 4.2	1
	Ammonia	15 ~ 25	2
	Amyl ether	3.1	1
	Aniline	6.9	1
	Arboreous cotton	1.3 ~ 1.4	1
	Asbestos	3.0 ~ 3.6	1
	Asbestos	3.0 ~ 3.5	1
Asphalt	2.5 ~ 3.2	1	
B	Bakelite	3.5 ~ 4.5	1
	Balm grounds	3.1	1
	Barley bran	1.8	1
	Barley flour	3.0 ~ 4.0	1
	Barley grain	3.0 ~ 4.0	1
	Barley hull	1.5	1
	Beeswax	2.5 ~ 2.9	1
	Benzene	2.3	1
	Benzine	2.3	1
	Benzyl alcohol	13	2
	Bone dust	5.0 ~ 6.0	1
	Borosilicic acid glass	4.5 ~ 6.2	1
	Bran	1.4 ~ 2.0	1
	Butanol	16 ~ 17	2
	Butyl alcohol	11	2
	Butyl chloride	7.4	1
Butylaldehyde	13	2	
Butylnitryl	20	2	
C	Calcite	8.3	1
	Calcium	3	1
	Calcium Carbonate	2.0 ~ 3.5	1
	Calcium hydroxide	2.0 ~ 3.5	1
	Calcium oxide	12	2
	Calcium phosphate	1.6 ~ 1.9	1
	Calcium sulfate	2.5 ~ 6.0	1
	Carbon bisulfide	2.6	1
	Carbon dioxide	1.6	1
	Casein resin	6.0 ~ 7.0	1
	Casting sand	3.4 ~ 3.5	1
	Cellophane	3.2 ~ 6.4	1
	Cellulose	3.2 ~ 7.5	1
	Cellulose acetate	3.2 ~ 7.0	1
	Cement powder	5.0 ~ 10	1
	Ceramic	4.0 ~ 7.0	1
	Cereal	3.0 ~ 8.0	1
	Charcoal	1.2 ~ 1.8	1
	CHCH3	12	2
	Chloride of lime	1.8 ~ 2.0	1
	Chlorobenzene	5.5 ~ 6.3	1
	Chloroform	4.8	1
	Chlorotoluene	4.0 ~ 4.5	1
	Chocolate	3.0 ~ 4.0	1
	Chrome	12	2
	Chromite	4.0 ~ 4.2	1
Clay	1.8 ~ 2.8	1	
Coal	4	1	
Cocoa grounds	2.5 ~ 3.5	1	
Coffee grounds	2.4 ~ 2.6	1	
Compound	3.6	1	
Copper oxide	18	2	

	Name of Object	SIC	S	
D	Corn	5.0 ~ 10	1	
	Corn husk	2.3 ~ 2.6	1	
	Cotton-seed oil	3.1	1	
	Cresol	9.0 ~ 11	2	
	Crude oil	2.48	1	
	Crystal	3.5 ~ 4.7	1	
	Curry powder	2.6	1	
	Cyclohexane	19	2	
	E	Decanol	8.1	1
		DEP dimethy	4.5 ~ 5.6	1
		Diallyl phthalein resin	3.3 ~ 6.0	1
		Diamond	2.2	1
		Dichloroethylene	4.6	1
		Diesel oil	1.8	1
		Diethyl ether	4.3	1
		Dolomite	8	1
F		Epoxy resin	2.5 ~ 6.0	1
		Ethanol	24	2
	Ethyl acetate	6.0 ~ 6.4	1	
	Ethyl ether	3.9 ~ 4.3	1	
	Ethyl iodide	7.8	1	
	Ethyl toluene	2.2	1	
	Ethylene dichloride	11 ~ 17	2	
	Ethylene glycol	37	2	
	Ethylene iodide	3.4	1	
	Ethylene oxide	4.0 ~ 5.0	1	
	Ethylene resin	2.2 ~ 2.3	1	
	Ethylene terafluoride	1.9 ~ 2.0	1	
	G	Feeding stuff	38	2
		Feldspar porcelain	5.0 ~ 7.0	1
		Ferric oxide	14	2
		Ferromanganese	5.0 ~ 5.2	1
Fiber		2.5 ~ 7.5	1	
Flour		2.5 ~ 3.0	1	
Fluid margarine		2.8 ~ 3.2	1	
Fluorine rubber		6.8 ~ 8.0	1	
Fluorite		6.8	1	
Fly ash		1.5 ~ 1.7	1	
Formaline		23	2	
Formamido		109	2	
Formic acid		58	2	
Freon		2.2	1	
H		Gasoline	2.0 ~ 2.2	1
		Glass	3.7	1
	Glass (granulated)	6.0 ~ 7.0	1	
	Glass-silicon board	3.5 ~ 4.2	1	
	Glycerin	47 ~ 68	2	
	Glycol	35 ~ 40	2	
	Granulated gelatine	2.6 ~ 2.7	1	
	Granulated sugar	1.5 ~ 2.2	1	
	Graphite	12 ~ 15	2	
	Gravel	5.4 ~ 5.6	1	
	Grout	3.0 ~ 5.0	1	
	Gum	2.7 ~ 2.9	1	
	I	Heavy oil	3	1
		Helium	1.1	1
		Heptanal	13	2
		Heptane	1.9 ~ 2.0	1
Hexane		5.8 ~ 6.3	1	
Hexanol		13	2	
Hydrochloric acid 100%		4.0-12	1	
Hydrofluoric acid		11 ~ 17	2	
I		Ink	2.5	1
		Iodine	11	2
		Isobutyl alcohol	18 ~ 40	2
		Isobutyl amine	4.5	1
		Ivory	6.9	1

SIC - Specific Inductive Capacity S - Sensitivity

*Please be advised that recommended SENSITIVITY depends on the conditions of the object to be measured, environments/temperature, and the shape of the electrode or its mounted conditions.

Line of business

- Rotary Paddle Type Level Switch
- Vibration Type Level Switch
- Swing Type Level Switch
- Acoustic Level Switch
- Capacitance Type Level Switch
- Capacitive Proximity Sensor
- Capacitance Type Level Indicator
- Diaphragm Type Level Switch
- Tilt Switch
- Leak Type Level Switch
- Microwave Switch
- Sounding Bob Type Level Indicator
- Flow Switch
- Electrode Type Level Switch
- Float Switch
- Float Type Level Indicator
- Ultrasonic Type Level Indicator
- Equipments For Conveyor Lines
- Dust Monitor System
- Zirconia Oxygen Analyzer
- Laser Type Level Indicator
- RADAR Type Level Indicator
- Ultrasonic Flow meter



All-round Manufacturer of Level Controllers for Powder, Granules and Liquid

KANSAI Automation **KANSAI Automation Co., Ltd.**

Headquarters: TEL. 81-6-6312-2071 FAX. 81-6-6314-0848
URL <http://www.kansai-automation.co.jp>
e-mail: infoe@kansai-automation.co.jp



SCIENCE GATE
Your Automation Partner



SCIGATE AUTOMATION (S) PTE LTD

No.1 Bukit Batok Street 22 #01-01 Singapore 659592

Tel: (65) 6561 0488

Fax: (65) 6562 0588

Email: sales@scigate.com.sg

Web: www.scigate.com.sg

Business Hours: Monday - Friday 8.30am - 6.15pm

Headquarters: 2-14, Togano-cho, Kita-ku, Osaka530-0056, Japan Tel 81-6-6312-2071 Fax 81-6-6314-0848
Tokyo Branch: 1-29-6, Hamamatsu-cho, Minato-ku, Tokyo105-0013, Japan Tel 81-3-5777-6931 Fax 81-3-5777-6933
Nagoya Office: 3-10-17, Uchiyama, Chigusa-ku, Nagoya464-0075, Japan Tel 81-52-741-2432 Fax 81-52-741-1588
Kyushu Office: 1-1-21, Komemachi, Kokura Kita-ku, Kitakyushu802-0001, Japan Tel 81-93-511-4741 Fax 81-93-511-4580

*Please be sure to read USER'S GUIDE, Installation & Operation Instructions when using the instrument.
*The specifications herein may be subject to change without advance notice.